

EXPLORER 1800



Our experience

Your key to success

KEESTRACK
MOBILE CRUSHING AND SCREENING EQUIPMENT



Applications

- Separation of aggregate
- Construction and demolition
- Screening behind a crusher
- Sand and gravel
- Quarrying
- Compost
- Coal
- Top soil and many other products

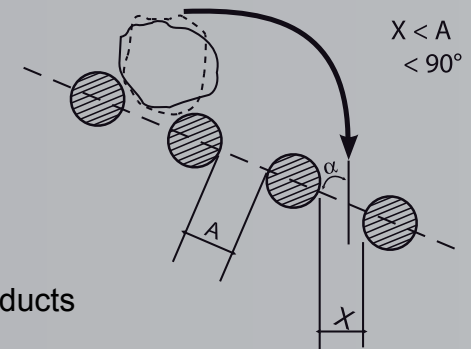

Features and benefits

Excellent access for screen mesh change

Free standing machine without support legs

Optimum flexibility and mobility with the highest possible performance

Low cost solution that offers superior screening results

State of the art Keestrack 2 - deck screenbox

Robust design with low machine weight

Up to 25% greater fuel efficiency

Compact transport dimensions

Low feeding height

Quick set-up time

Proven reliability





*Our experience
Your key to success*

TECHNICAL SPECIFICATIONS:

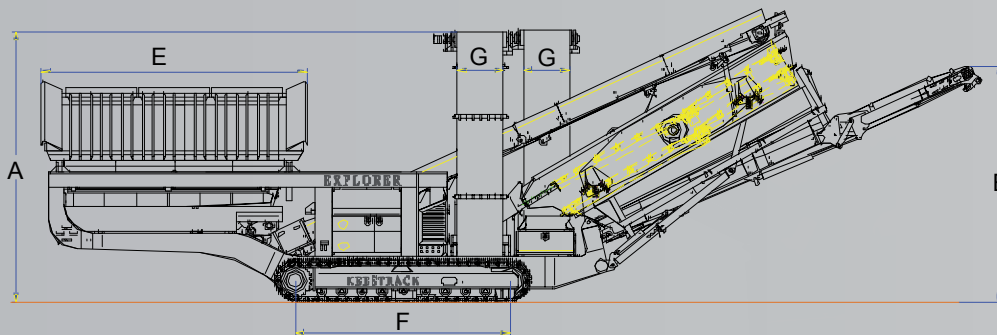
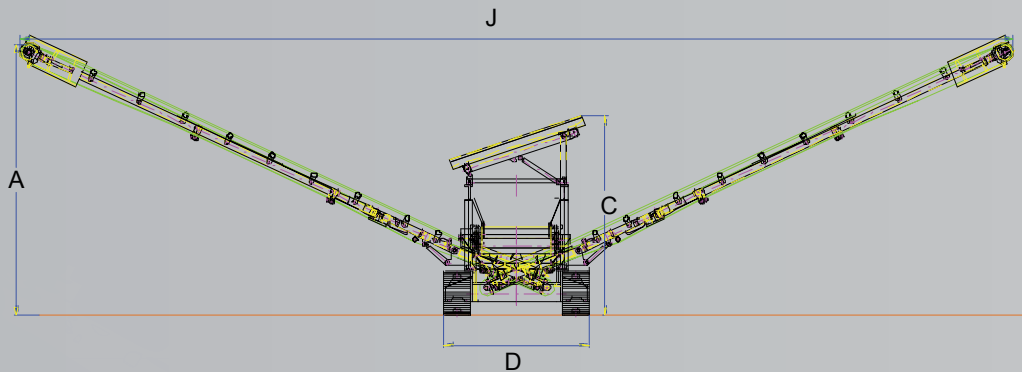
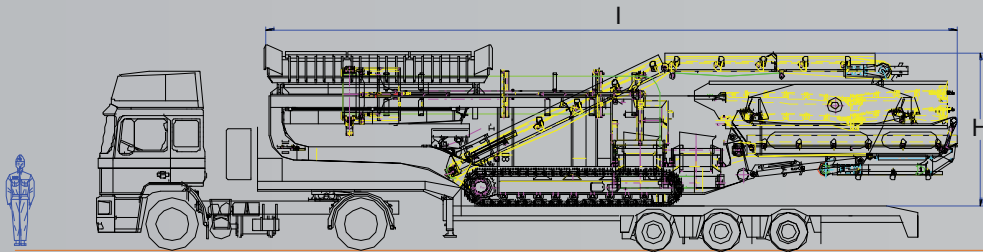

A	B	C	D	E	F	G	H	I	J	
4680	3250	3450	2500	4570	3720	800	3100	14300	17135	mm
15' 4"	10' 8"	11' 4"	9' 10"	15' 0"	12' 2"	32"	10' 2"	46' 11"	56' 2"	ft inch

	2 deck	3 deck
Transport height	: 3100 mm	3300mm
Transport width	: 2500 mm	3000mm
Transport weight	: aprox. 28 ton	approx. 31 ton

Pos.1) Feedhopper : 7,7 m³ 9,62 yards
 The grid is hydraulic tipping

Pos.2) Belt feeder
 Full adjustable speed : 0 to 6.1 m/min. 0 - 20 ft/min

Pos.3) Screenbox : KT-4818 MD
 Length X width : 4500 mm x 1800 mm, 8,1 m² 15' x 6'
 Drive : hydraulic, 11 KW 15 hp

Pos.4) Conveyor belt under screenbox(fines material)
 Length : 6750 mm 22' - 2"
 Width : 1200 mm 48"
 Drive : hydraulic, 7,5 KW 10 hp

Pos.5) Main conveyor
 Type : KT-95/1200
 Length x width : 9500 mm x 1200 mm 31' - 2" x 48"

Pos.6) Side conveyor left (mid size material)
 Length x width : 10.000 mm x 800 mm 32" - 2" x 32"
 Drive : hydraulic, 15 KW 20 hp

Pos.7) Side conveyor right (oversize material)
 Length x width : 10.000 x 800 mm 32" - 2" x 32"
 Drive : hydraulic, 7,5 Kw 10 hp

Pos.8) Trackdrive D4E
 Length x width : 3750 mm x 450 mm 12'-4" x 18"
 Speed : Max 1.45 km/h. 1,8 mph

Pos.9) Power unit : Diesel/hydraulic
 Engine type : DEUTZ 91 KW 123 hp
 Hydraulic : SAUER/DANFOSS, load-sensing

All measurements are approximate.

EXPLORER 1800

OPTIONS LIST

1. Three deck screen
2. Radio remote control
3. Diesel fill pump 80 l / min
4. Working lamps (3)
5. Anti clogging system bottomdeck
6. Tungsten steel beltscraper on underscreen conveyor
7. Rubberdeck topdeck
8. S flex screen mat
9. Overband magnet on main conveyor
10. Vibrating grid
11. Low infeed belt feeder

Powered by:

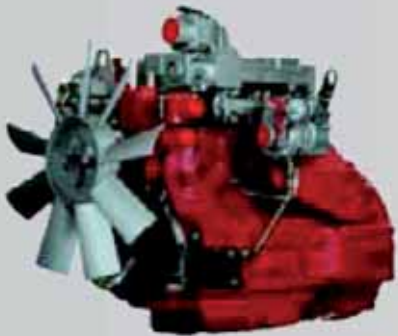

1



2



3



4



5



6

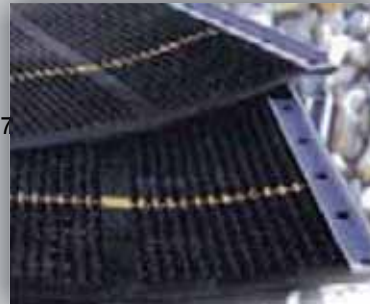

7



8



9



10



11



Our Experience

Your key to success

The material in this document is for information only and is subject to change without notice. Keestrack N.V. assumes no liability resulting from errors or omissions in this document, or from the use of the information contained herein.

Les renseignements contenus dans ce document ne sont fournis qu'à titre d'information uniquement et peuvent être modifiés sans avis préalable. Keestrack N.V. décline toute responsabilité résultant d'erreurs ou d'omissions dans ce document, ou de l'utilisation des renseignements y figurant.

Materialet i dette dokumentet er kun til informasjon og kan endres uten varsel. Keestrack NV påtar seg ikke ansvar som følge av feil eller utelatelser i dette dokumentet, eller fra bruk av informasjonen i dette dokumentet.

Der inhalt dieses Dokuments ist nur zur information bestimmt und kann ohne vorherige Bekanntgabe geändert werden. Keestrack N.V. übernimmt für Fehler oder Auslassungen oder für die Anwendung der enthaltenen informationen keine Haftung.

Il materiale contenuto in questo depliant è solamente a titolo informativo e può essere cambiato senza alcun preavviso. Keestrack N.V. non assume responsabilità per eventuali errori od omissioni o per l'uso delle informazioni contenute.

De gegevens in dit document zijn alleen ter informatie bedoeld en kunnen ten alle tijde zonder verwittiging veranderd worden. Keestrack N.V. is niet verantwoordelijk voor eventuele drukfouten, onvolledigheden of voor het gebruik van de informatie in deze folder.

Head office:
Keestrack nv
Taunusweg 2
3740 Bilzen - Belgium
Tel: +32 89 51 58 51
info@keestrack.net
marketing@keestrack.net
www.keestrack.com

Třídíč s.r.o.
Pískovište 1663/3
78501 Šternberk - Czech Republic
Tel: +420 585 002 031
marketing2@keestrack.net
www.tridic.com

Keestrack of America
3550 Fairfield Road
Baltimore MD 21226 USA
Tel: +1 410 355 1377
sparesusa@keestrack.net

Keestrack (Chuzhou) Construction
Equipment Co., Ltd
Add: Cheng Dong Industry Park,
Chuzhou, AnHui 239000, P.R.C
Tel: +86 (0) 550 356 25 05
sales.china@keestrack.net
www.keestrackchina.com

Keestrack Technology Center Pvt Ltd
Classic Packaging Industry Building
FF , Plot no L-148 & 149
Verna Industrial Estate,
Verna, Goa-403722
Tel: +91 7875 446 007
info@keestrack-ktc.com

OMTRACK srl
Via Postumia 62
31050 Ponzano Veneto/Treviso
Italy
Tel: +39 0422 44 13 11
omtrack@omtrack.it
www.omtrack.it

